

IWR-1

SINGLE CHANNEL WIRELESS RECEIVER



The IWR-1 is a single channel receiver designed to pair with IWPT & IWTT wireless pressure & temperature transmitters to form a cost-effective replacement of traditional wired transducers. This offers a low cost solution to inaccessible or expensive installation environment.

The receiver has a user selectable voltage or mA output corresponding to the calibrated range of the remote Wireless Transducer and 5A rated changeover contacts for alarm functionality.

User configuration is possible, however the single channel transmitter/receiver combination is designed to work 'out of the box' offering a simple plug and play solution to remote measurement applications. With the standard 0dBI antenna, a line-of-sight range of up to 500 m can be achieved and, using the optional 3dBI antenna, up to 750m (LOS) is achievable.

Features

- Pairs with the IWPT/U & IWTT/U wireless pressure & temperature transducers
- User-selectable 1-5V or 4-20 mA receiver output
- Clean contact output for process, low battery or loss of signal alarm function
- Simple DIL switch pairing with the IWPT/U & IWTT/U transmitters
- Up to 500 m range, line-of-sight
- 12 to 32 V dc powered
- End-to-end accuracy of $\pm 0.25\%$ FS BFSL
- LED indication of wireless link
- DIN rail or wall mounting kits available
- Five channel receiver available - see data sheet IWR-5

SPECIFICATIONS

Electrical Protection

Outputs*	User selectable 1-5V or 4-20 mA
Alarm Output	5 Amp rated changeover contacts
Receiver Update Rate**	10 seconds as standard
	Alternative user settable rates: - 1, 5, 10 and 30 seconds

*Factory preset is 4-20 mA output

**Consult IWPT/IWTT Installation manual and data sheet for set-up of alternative transmission rates.

Enclosure Specifications

Dimensions	120 mm x 80 mm x 57 mm
Material*	Light grey ABS (RAL7035)
Protection Class	IP65
Weight	215g inc. 0dBI antenna (+12g with 3dBI)
Installation Position**	Any

*Other materials on request.

**Consult Installation Manual to ensure adequate signal path between transmitter and receiver.

Receiver Input

Receiver Frequency*	2.4GHz
System Channel	Standard setting, however user adjustable in multiple instrument systems
Antenna	Enclosure mounted 0dBi

*Compliant with EN 300 328, V1.8.1

System Performance (@ +20°C)

Accuracy	<±0.25% FS BFSL
Setting Errors (offsets)*	Zero and Full Scale <±0.5% FS

*End-to-end zero tare function available, see user manual.

Instrument Power Source

DC Power	12 to 32 V dc
-----------------	---------------

Temperature Ratings

Operating Temperature	-10°C to +50°C
Storage Temperature	-20°C to +80°C

DIMENSIONS

All dimensions are in millimeters.

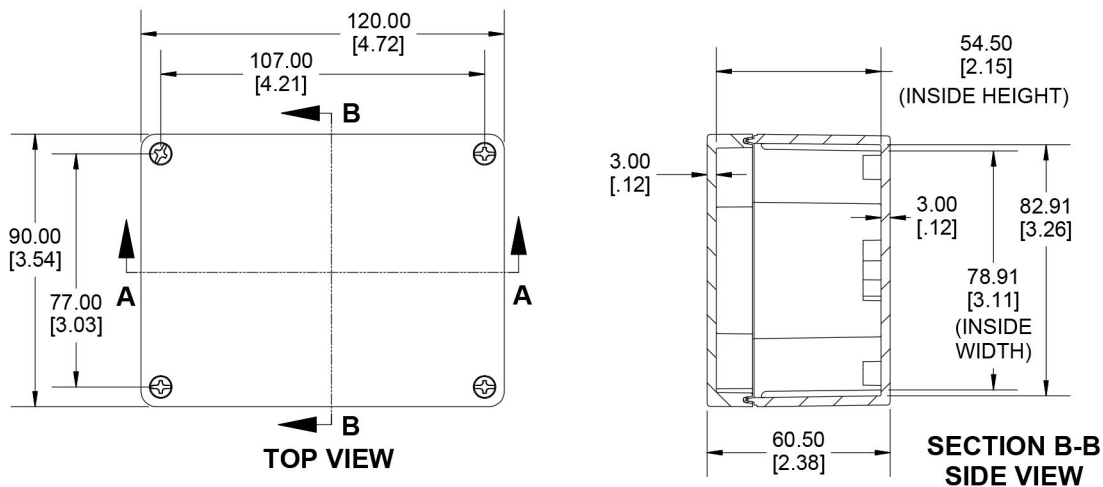

ORDERING OPTIONS

Example : IWR-1

Transmitters	See IWPT & IWTT datasheets
Single Channel Receiver	IWR-1
Five Channel Receiver	IWR-5
Five Channel Configuration Software*	IWR-Set
3dBi Antenna (enclosure mount)	IANT-3