

**FREQCON-6**  
**24V AC or DC POWERED**  
**ISOLATING SIGNAL CONVERTER**

Whilst every effort has been taken to ensure the accuracy of this document, we accept no responsibility for damage, injury, loss or expense resulting from errors or omissions, and reserve the right of amendment without notice.

Industrial Interface

This document may not be reproduced in any way without the prior written permission of the company.

June 2007

---

## CONTENTS

<b>1. INTRODUCTION</b>	<b>3</b>
1.1 Hardware Features	3
1.2 Isolation Details	3
<b>2. UNPACKING</b>	<b>3</b>
<b>3. CONNECTIONS</b>	<b>4</b>
<b>4. CONFIGURING THE FREQCON</b>	<b>5</b>
4.1 Frequency Input	6
4.2 Input types	7
4.3 Averaging and Stepchange Adjustment	8
4.4 Averaging	8
4.5 Stepchange	9
4.6 Interaction	10
4.7 Output Configuration	11
<b>5. CALIBRATING THE FREQCON</b>	<b>12</b>
<b>6. INSTALLATION</b>	<b>13</b>
<b>7. TROUBLESHOOTING</b>	<b>14</b>
7.1 Incorrect Reading	14
7.2 Sensor Failure	14
<b>8. SPECIFICATIONS (@ 25°C)</b>	<b>15</b>

Industrial Interface Systems Ltd  
sales@industrialinterface.co.uk  
www.industrialinterface.co.uk

## 1. INTRODUCTION

### 1.1 Hardware Features

The FREQCON-6 is a Frequency to Analogue Signal Converter. It supports a wide range of signal inputs, from Hall effect transducers to +-24V signals. It also produces 3 types of analogue output; voltage, mA source, or mA sink.

The unit can be powered by any DC voltage between 12 and 36Vdc or 12 and 32Vac.

The instrument is packaged in a very compact 12.5mm wide enclosure which can be mounted on standard TS35 DIN-rail.

### 1.2 Isolation Details

The FREQCON-6 has full 3 port isolation of 1000V between the Input Stage, Output Stage and Power Supply for functional reasons.

## 2. UNPACKING

The instrument should be carefully inspected for signs of damage which may have occurred in transit. In the unlikely case that damage has been sustained, DO NOT use the instrument, but please retain all packaging for our inspection and contact your supplier immediately.

The instrument comes with the following items as standard:

- 1 Freqcon-6 Isolating Signal Converter
- 1 Freqcon-6 User Guide

If the instrument has been factory configured the input and output details will be listed on the Serial number label on the side of the unit. If this label is blank then the unit will be set to its default configuration which is 0-10kHz logic level input and 4-20mA source output. Please check that the details on the side label are correct, especially the power supply voltage.

If re-configuration is required please refer to Section 4 of this manual.

### 3. CONNECTIONS

The FREQCON is housed in a compact DIN rail mounting enclosure, with 8 terminals, arranged in 4 rows of 2 terminals. Two rows are at the top of the front panel and 2 rows are at the bottom. All the sensor input terminals are on the bottom rows and the power supply and analogue outputs are on the top terminals.

The diagram below shows how to connect all the different input, output and power supply types.

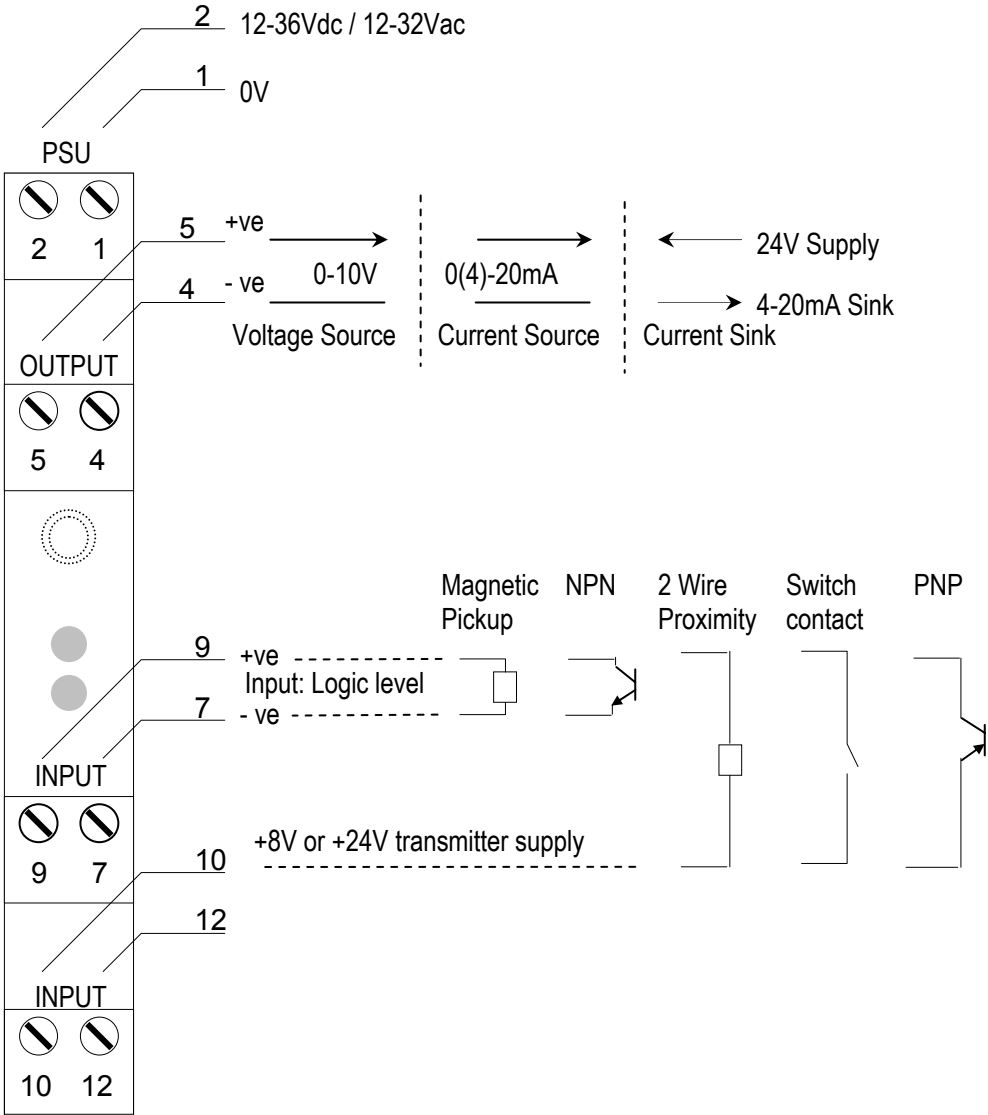

## 4. CONFIGURING THE FREQCON



**! WARNING !**  
**DO NOT OPEN UNIT OR ADJUST SWITCHES WITH  
 POWER SUPPLY, INPUT OR OUTPUT CONNECTED**

The FREQCON is an extremely versatile device which can support many different types of frequency input. The unit is configured by turning the power off, selecting the internal switch settings required and turning the power back on.

To open the Freqcon, 2 catches just below the outer terminal blocks must be pushed in gently, one at a time. The front of the case can then be pulled and the unit will come out of the box.

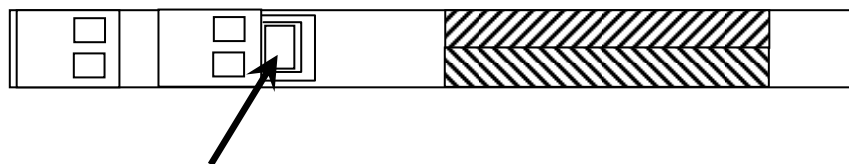

Press here gently

There are 2 switch banks, S1 and S3, located inside the FREQCON as shown below:

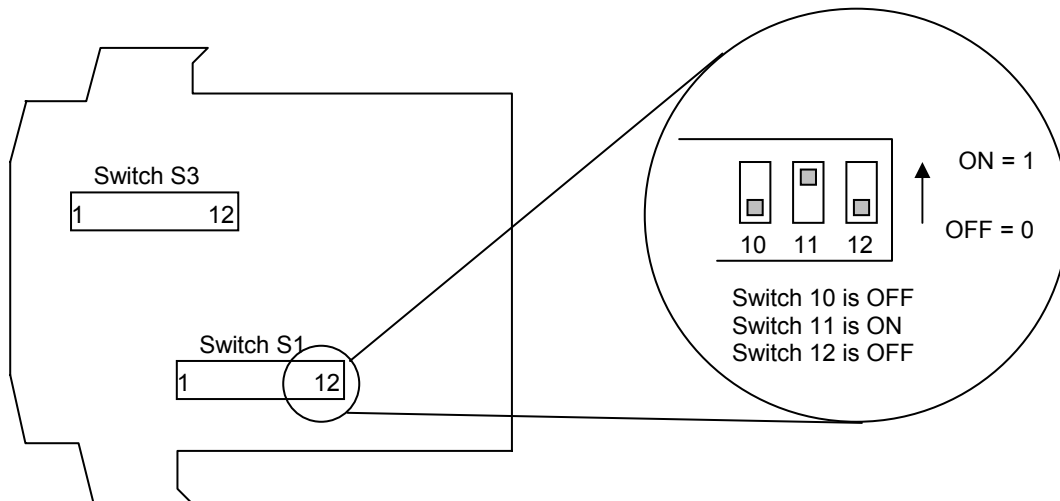

Switch S1 configures the input type and range and switch S3 configures the output type, range and a few additional functions. The switch settings are explained in the next few pages. The diagrams refer to switch positions 0 and 1, with 0 being OFF and 1 being ON. This is illustrated in the picture above.

### 4.1 Frequency Input

Select the range from the table below and set Switch S1 to the required values. Switches 1 to 8 control the input type, while switches 9 to 12 control the input frequency range.

Input Frequency (Hz)	Switch S1											
	1	2	3	4	5	6	7	8	9	10	11	12
0 to 0.01									0	0	0	0
0 to 0.03									1	0	0	0
0 to 0.1									0	1	0	0
0 to 0.3									1	1	0	0
0 to 1									0	0	1	0
0 to 3									1	0	1	0
0 to 10									0	1	1	0
0 to 30									1	1	1	0
0 to 100									0	0	0	1
0 to 300									1	0	0	1
0 to 1000									0	1	0	1
0 to 3000									1	1	0	1
<b>0 to 10000</b>									<b>0</b>	<b>0</b>	<b>1</b>	<b>1</b>
0 to 30000									1	0	1	1
0 to 100000									0	1	1	1
0 to 250000									1	1	1	1



**! WARNING !**  
**DO NOT OPEN UNIT OR ADJUST SWITCHES WITH  
 POWER SUPPLY, INPUT OR OUTPUT CONNECTED**

Please note that PC Software is available to provide information on switch settings for your input and output requirements.

## 4.2 Input types

Select the range from the table below and set Switch S1 to the required values.

Input Type	Switch S1											
	1	2	3	4	5	6	7	8	9	10	11	12
TTL Logic	0	0	0	0	0	0	1	0				
2 Wire Proximity	0	0	0	1	0	0	1	0				
Switch Contact	1	1	0	0	0	0	1	0				
NPN transistor	0	0	0	0	0	1	1	0				
PNP transistor	0	0	1	0	0	0	1	0				
Mag Pickup	1	0	0	0	0	0	0	0				

The switching threshold can be adjusted to allow smaller signals to be picked up and counted. S1 switches 5 and 7 control this. The threshold voltage in the table below indicates the voltage level at input terminal 9 that the signal must exceed for it to be counted and the frequency calculated.

5	7	Threshold
Off	Off	0.25 V
Off	On	4.00 V
On	Off	0.10 V
On	On	2.08 V

+8V transmitter supply is always available on input 10. Switch 8 will increase the transmitter supply to +24V.



**! WARNING !**  
**DO NOT OPEN UNIT OR ADJUST SWITCHES WITH**  
**POWER SUPPLY, INPUT OR OUTPUT CONNECTED**

Please note that PC Software is available to provide information on switch settings for your input and output requirements.

### 4.3 Averaging and Stepchange Adjustment

Averaging and stepchange are controlled by the pots situated next to S1:

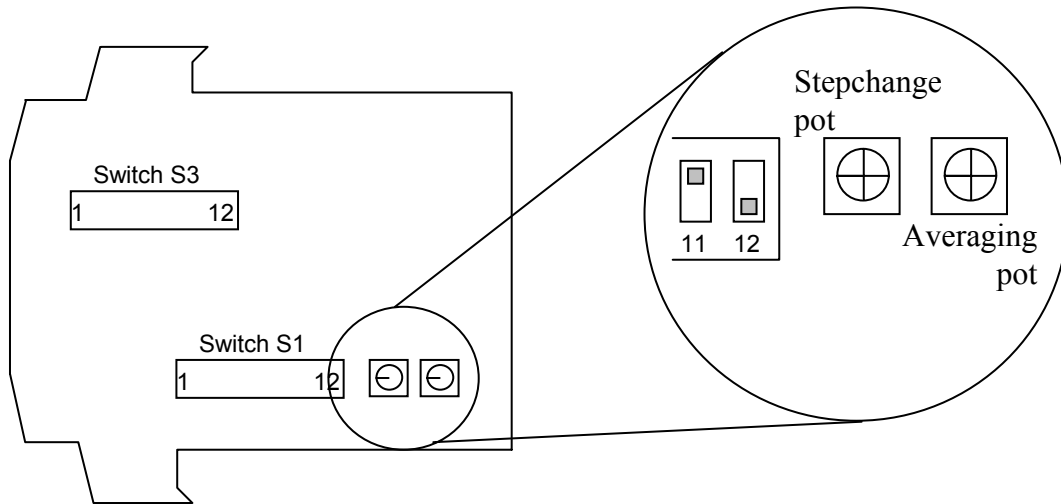

### 4.4 Averaging

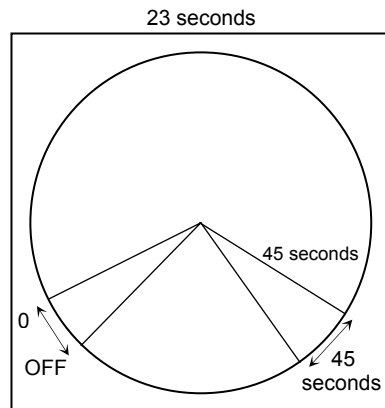

Fully anticlockwise : Averaging off

Fully clockwise : Averaging over 45 seconds approx.

Averaging is performed by storing a running total of the previous samples, adding the new sample value to this running total, then dividing by the total number of samples to get the average. The oldest sample is then subtracted from the running total. When a step change occurs, the running total is reset to 0, so that averaging can recommence at the new level.

The pot level must be set when the power is off. The pots are read at power up.



## 4.5 Stepchange

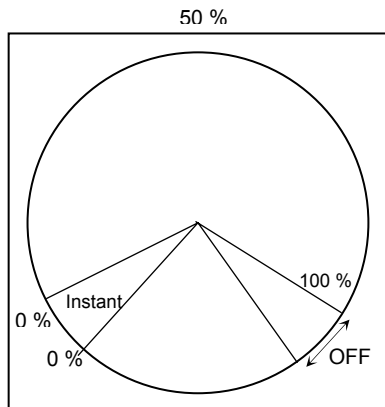

- At 0%, a stepchange will occur if the change in frequency is greater than 0% of full scale. Since this is true for every change in frequency, stepchange will occur instantly, negating the affects of averaging.
- At 50%, a stepchange will occur if the change in frequency is greater than 50% of full scale.
- At 100%, a stepchange will occur if the change in frequency is greater than 100 % of full scale. Since this is impossible, stepchange is off when this pot is fully clockwise.

Fully anticlockwise : 0%

Fully clockwise : 100%

Example: 0 to 10,000 Hz input range, 50% stepchange, average over last 100 samples.

Input is 8,000 Hz and drops to 4,000 Hz. No stepchange will occur because the fall was 4,000Hz which is only 40% of full scale, new 4000 Hz value will be averaged into the current running total.

Example 2: 0 to 10,000Hz, 50% stepchange

Input 8,000Hz drops to 2500Hz. Stepchange occurs and output changes immediately. Averaging starts again at 2500 Hz

The pot level must be set when the power is off. The pots are read at power up.

## 4.6 Interaction

There is interaction between stepchange and averaging. If the frequency changes by more than the stepchange value causing a stepchange, the number of samples the new frequency is averaged over will be reset to 0, causing a less averaged interpretation of the input frequency for a few seconds until enough new samples have been taken to average the current reading against.

If averaging is on and stepchange is at 0%, averaging will not work because the stepchange will happen every time the frequency changes, causing the values used to calculate the average to be reset each time.

## 4.7 Output Configuration

Select the range from the table below and set Switch S3 to the required values.

Switch S3 - Output Configuration																																																	
1	2	3	4	5	6	7	8	9	10	11	12																																						
<table border="1"> <tr> <td>0</td><td>1</td><td>0</td><td>1</td><td>0</td><td><b>mA Source</b></td> </tr> <tr> <td>1</td><td>0</td><td>1</td><td>0</td><td>0</td><td>mA Sink</td> </tr> <tr> <td>0</td><td>1</td><td>0</td><td>1</td><td>1</td><td>Voltage</td> </tr> </table>						0	1	0	1	0	<b>mA Source</b>	1	0	1	0	0	mA Sink	0	1	0	1	1	Voltage	<table border="1"> <tr> <td>0</td><td><b>Normal</b></td> </tr> <tr> <td>1</td><td>Inverted o/p</td> </tr> </table>		0	<b>Normal</b>	1	Inverted o/p	<table border="1"> <tr> <td>0</td><td><b>Normal</b></td> </tr> <tr> <td>1</td><td>Square Root</td> </tr> </table>		0	<b>Normal</b>	1	Square Root	<table border="1"> <tr> <td>4-20mA / 2-10V</td><td>0</td><td>0</td> </tr> <tr> <td>0-20mA / 0-10V</td><td>0</td><td>1</td> </tr> <tr> <td>0-10mA / 0-5V</td><td>1</td><td>0</td> </tr> <tr> <td>2-10mA / 1-5V</td><td>1</td><td>1</td> </tr> </table>		4-20mA / 2-10V	0	0	0-20mA / 0-10V	0	1	0-10mA / 0-5V	1	0	2-10mA / 1-5V	1	1
0	1	0	1	0	<b>mA Source</b>																																												
1	0	1	0	0	mA Sink																																												
0	1	0	1	1	Voltage																																												
0	<b>Normal</b>																																																
1	Inverted o/p																																																
0	<b>Normal</b>																																																
1	Square Root																																																
4-20mA / 2-10V	0	0																																															
0-20mA / 0-10V	0	1																																															
0-10mA / 0-5V	1	0																																															
2-10mA / 1-5V	1	1																																															
<table border="1"> <tr> <td>0</td><td>Buttons Disabled</td> </tr> <tr> <td>1</td><td><b>Buttons Enabled</b></td> </tr> </table>		0	Buttons Disabled	1	<b>Buttons Enabled</b>	<table border="1"> <tr> <td><b>High Burnout</b></td><td>0</td> </tr> <tr> <td>Low Burnout</td><td>1</td> </tr> </table>		<b>High Burnout</b>	0	Low Burnout	1																																						
0	Buttons Disabled																																																
1	<b>Buttons Enabled</b>																																																
<b>High Burnout</b>	0																																																
Low Burnout	1																																																
<p>Output value if fault on input signal</p>																																																	
<p>Front panel buttons can be disabled to allow tamper-proof operation of unit</p>																																																	

Examples:

Switch S3 Examples												
	1	2	3	4	5	6	7	8	9	10	11	12
4-20mA Source	1	0	1	0	1	0	0	0	0	0	0	0
0-20mA Source	1	0	1	0	1	0	0	0	0	0	0	1
0-10V	1	0	1	0	1	1	0	0	0	0	0	1
4-20mA Sink	1	1	0	1	0	0	0	0	0	0	0	0



**! WARNING !**  
**DO NOT OPEN UNIT OR ADJUST SWITCHES WITH POWER SUPPLY, INPUT OR OUTPUT CONNECTED**

Please note that PC Software is available to provide information on switch settings for your input and output requirements.

## 5. CALIBRATING THE FREQCON

When the unit is shipped the FREQCON will be calibrated for the input and output types and ranges noted on the side label. If this label is blank then the unit will be calibrated for 0-10kHz logic level input and 4-20mA source output.

If the unit is re-ranged by the user it is necessary to re-calibrate the unit to obtain the maximum accuracy. The calibration is achieved by using both switches on the front panel to select the zero or span input and then using the switches as raise/lower buttons to adjust the output to the value required.

The mode the unit is in is indicated by the colour of the LED:

Green	-	Normal Operation
Red	-	Span Adjust
Yellow	-	Zero Adjust

Setting of the zero and span points is non-interactive, so each point need only be set once. A typical calibration sequence would be as follows:

LED Colour	Mode	Action
Green	Normal	Apply full scale input. Press and release both buttons together to enter span mode
RED	Span Adjust	Press raise / lower buttons to adjust output value Press and release both buttons together to return to normal mode
Green	Normal	Apply zero scale input Press and release both buttons together to enter zero mode
YELLOW	Zero Adjust	Press raise / lower buttons to adjust output value Press and release both buttons together to return to normal mode
Green	Normal	Use product

The unit is now calibrated and ready for use.

Note: The unit will retain the new settings on power down.

## 6. INSTALLATION

The FREQCON input and output circuits are classed as Separated Extra Low Voltage (SELV). This means that they must not be externally connected to voltages exceeding 30V ac or 60V dc, nor do they generate voltages above these limits internally. Where a higher voltage input is required a specially designed DIVIDER unit can be used to condition the input signal prior to connection to the process input terminals.

The FREQCON unit clips directly onto 'Top Hat' (TS35) symmetrical DIN rail. Ideally, mounting orientation should be vertical, with the power supply situated on the top face to minimise temperature rise. Good airflow around the unit will maximise reliability of the instrument.

The use of bootlace ferrules is recommended on wiring terminations.

Do not exceed terminal torque rating of 0.4 Nm – use an appropriate screwdriver. The unit can be removed from the DIN rail by sliding a small screwdriver into the slot at the rear of the enclosure on the lower face and gently levering the metal clip, whilst lifting the unit from the rail.

## 7. TROUBLESHOOTING

The FREQCON has some built in self diagnostic functions. If the LED on the front panel is flashing then the fault mode can be found by counting the number of flashes between gaps and using the table below to locate the problem.

No of Flashes	Nature of Fault	Corrective Action
0 (Green On)	Unit Working – no suspected fault	Check Wiring and switch settings
2,3,4,5,6,8,9, 10,11,12 Green	Hardware Error, extreme noise, poor supply	Switch off unit, check switch settings, and wiring, and retry. If still faulty please contact supplier
7 Green	Frequency out of scale burnout	Reduce frequency
3 or 4 Red	Span point is too close to zero point	Change input span value and retry
3 or 4 Yellow	Zero point is too close to span point	Change input zero value and retry
No LED	Power Failure	Check supply lines and voltage

### 7.1 Incorrect Reading

- Check that Unit is configured for the correct Sensor
- Check that Input Scaling is as required.
- Check that Linearisation has not been set incorrectly.

### 7.2 Sensor Failure

- Check that sensor wiring is correct.
- Check that the FREQCON is configured for correct sensor.
- Check that frequency is not out of range.

## 8. SPECIFICATIONS ( @ 25°C)

Operating Temperature	0 to 55 °C
Operating Altitude	Sea Level to 2000m
Humidity	0-90% RH
Power Requirements	
DC Supply	12 to 36Vdc
AC Supply	12 to 32Vac
Current Consumption	110mA @ 24Vdc (NPN O/C in, 20mA out) 109mA @ 24Vdc (TTL logic in, 20mA out)
Transmitter Power Supply	8V or 22V to 29V @ up to 24mA Dependant on supply voltage and load
Calibration accuracy	±0.01% full scale
Linearity	±0.01% full scale
Temperature Stability	27ppm / °C
Maximum Voltage Output	11.5 V into a minimum of 7Kohm
Maximum Current Output	23.0 mA into a maximum of 1Kohm
Time Response (90% of step change):	50ms ± 10ms
Unit has full 3 port Isolation to 1kV between Power Supply, Input and Output. The unit can also withstand transients of 2.5kV for 50 µsecs.	
Dimensions	114.5 mm x 99mm x 12.5mm (H x D x W)
Mounting	DIN Rail TS35
Connections	Screw Clamp with pressure plate
Conductor Size	0.5 to 4.0 mm
Insulation Stripping	12 mm
Maximum Terminal Torque	0.4 Nm
Weight	Approx. 95g
EMC	BS EN61326
LVD Standards	EN61010-1
Installation Category (IEC 664)	II
Pollution Degree (EN61010-1)	2
Equipment Class (IEC 536)	II