

# IWR-5

## Five Channel

### Industrial Wireless Pressure/Temperature Receiver



Whilst every effort has been taken to ensure the accuracy of this document, we accept no responsibility for damage, injury, loss or expense resulting from errors or omissions, and reserve the right of amendment without notice.

This document may not be reproduced in any way without the prior written permission of the company.

Issue 2 August 2018

Industrial Interface Systems Ltd  
Units 68 & 69 Basepoint Business Centre  
Oakfield Close, Tewkesbury, GL20 8SD, United Kingdom  
Tel: +44(0)1684 854464, email: sales@industrialinterface.co.uk

[www.industrialinterface.co.uk](http://www.industrialinterface.co.uk)

## CONTENTS

<b>1. INTRODUCTION</b>	<b>2</b>
<b>1.1 Safety Information</b>	<b>2</b>
<b>1.2 Hardware Features</b>	<b>2</b>
<b>2. UNPACKING</b>	<b>2</b>
<b>3. IWR-5 Receiver set up procedure</b>	<b>3</b>
<b>4. TROUBLE-SHOOTING GUIDE</b>	<b>6</b>
<b>5. SYSTEM PART NUMBERS</b>	<b>7</b>
<b>6. SPECIFICATIONS</b>	<b>7</b>

## 1. INTRODUCTION

### 1.1 Safety Information

This manual contains information that must be observed in the interest of your own safety and to avoid damage to assets. Please read this manual before installing and commissioning the device and keep the manual in an accessible location for all users.

To satisfy FCC RF Exposure requirements for mobile and base station transmission devices, a separation distance of 20cm or more should be maintained between the antenna of this device and persons during operation. To ensure compliance operation at closer than this distance is not recommended. The antenna used for this transmitter must not be co-located or operating in conjunction with any other antenna or transmitter

### 1.2 Hardware Features

The IWR range of Wireless Pressure & Temperature Receivers has been designed to receive the values from Wireless Pressure & Temperature transmitters and output the measured value as 4-20mA or 1-5Vdc analogue output signals.

The IWR-1 has a single output and the IWR-5 has five outputs, each of which can be linked to an individual transmitter.

The IWR range of receiver units operate on the licence-free 2.4GHz frequency band.

Ranges of up to 500m are possible using the standard transmitter and receiver units with the supplied antennas. The actual achieved ranges can be adversely effected by obstacles (particularly metals), walls, trees, vehicles, etc., in between the transmitter and receiver.

The receiver is powered by a DC voltage of 12-32Vdc.

## 2. UNPACKING

The instrument should be carefully inspected for signs of damage which may have occurred in transit. In the unlikely case that damage has been sustained, DO NOT use the instrument, but please retain all packaging for our inspection and contact your supplier immediately.

### 3. IWR-5 Receiver set up procedure

The IWR-5 receives data from up to 5 off wireless pressure or temperature transmitters and produces 4-20mA or 1-5Vdc analogue outputs representing 0 - 100% of each of the wireless transmitters connected.

It also has an alarm output that can be used as a high/low, loss of signal or low battery alarm. As delivered the IWR-5 is configured to receive transmissions from IWPT and IWTT wireless pressure transmitters configured from channel 1 to channel 5.

#### Connections and Configuration Switches

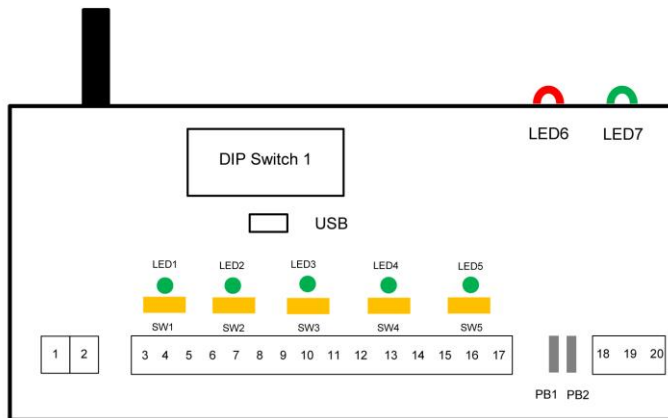

Terminal Number	Connection
1	Power 0V
2	Power +ve
3	Output 1 0V
4	mA Output 1 +ve
5	1-5Vdc Output 1 +ve
6	Output 2 0V
7	mA Output 2 +ve
8	1-5Vdc Output 2 +ve
9	Output 3 0V
10	mA Output 3 +ve
11	1-5Vdc Output 3 +ve
12	Output 4 0V
13	mA Output 4 +ve
14	1-5Vdc Output 4 +ve
15	Output 5 0V
16	mA Output 5 +ve
17	1-5Vdc Output 5 +ve
18	Relay Common
19	Relay N.C
20	Relay N.O

**Dipswitch**

**Configuration**

The 8 way Dipswitch 1 is used to configure the basic functionality of the IWR-5

The RF network code must be the same as the IWPT units to be used with the receiver unit.

Switches 1, 2, 3 & 4 select the network code as below

<b>RF NETWORK</b>	<b>1</b>	<b>2</b>	<b>3</b>	<b>4</b>
1	0	0	0	0
2	0	0	0	1
3	0	0	1	0
4	0	0	1	1
5	0	1	0	0
6	0	1	0	1
7	0	1	1	0
8	0	1	1	1
9	1	0	0	0
10	1	0	0	1
11	1	0	1	0
12	1	0	1	1
13	1	1	0	0
14	1	1	0	1
15	1	1	1	0
16	1	1	1	1

Switch 5 and 6 select the number of transmissions which are missed before the Alarm relay output switches to the alarm condition.

<b>Missed Transmissions</b>	<b>5</b>	<b>6</b>
4	0	0
2	0	1
6	1	0
No Alarm	1	1

Switch 7 and 8 Configure the action of the Alarm Relay output. This can also be configured to exact alarm values using the USB port and the IWR-Set software.

<b>Relay Action</b>	<b>7</b>	<b>8</b>
Relay 1 switches OFF any I/P above 50%	0	0
Relay 1 switches OFF any I/P above 75%	0	1
Relay 1 switches OFF any I/P above 25%	1	0
Relay 1 Configured via USB & IWR-Set software	1	1

## LED Indication

LED 6 is used to indicate the status of the alarm relay. This is lit if any of the values transmitted are outside the alarm limit, the receiver has missed the number of transmissions configured above or flashes if the transmitter has a low battery capacity.

LED 7 flashes when a valid transmission is received from any connected transmitter.

There is also an indicator LED for each output channel of the IWR-5. These are used to indicate the following alarm conditions for each channel:

LED Flashes 2 times:	This indicates that the number of transmissions missed has exceeded the number set up by Switches 5 & 6 above.
LED Flashes 3 times:	This indicates that the value for that channel is outside the limits selected by switches 7 & 8 above.
LED Flashes 4 times:	This indicates the transmitter linked to this channel has a low battery level.

### Output Calibration

The IWR-5 is factory calibrated for 4-20mA and 1-5V source outputs so that if a sensor transmits a zero or full scale output the IWR-5's output for that channel will be within its accuracy specifications.

The output selector switches are used to select either 4-20mA & 1-5Vdc for each channel. Push the switch SW1 to the left to select 4-20mA and to the right to select 1-5Vdc

It is possible to adjust the outputs to match the equipment used to monitor the output or to compensate for any zero or span drift of the transmitters. This is achieved by using the pushbuttons PB1 (DOWN) and PB2 (UP) and the internal LEDs as outlined here:

- Push both buttons at same time then release to put the unit into zero tare mode starting with Channel 1.
- LED1 will go amber, and output one will change to the zero value.
- Ensure there is no pressure or temperature applied to the connected transmitter and then use the DOWN and UP buttons to adjust the output to be 4mA or 1V
- If the LED flashes amber this indicates that the connected transmitter zero value is not valid.
- Push both buttons at same time again and then release.
- LED1 will go red to indicate that the full scale output will be adjusted. Inject the full scale pressure or temperature range into the sensor using a Calibrator. If no Calibrator is available press both buttons again to exit the calibration mode saving only the zero tare value. The LED will go amber for 0.5 seconds as the zero tare value is learnt and saved to memory.
- If the full scale pressure can be applied use the DOWN (PB1) and UP (PB2) buttons to adjust the output to be 20mA or 5V. When the output is correct push both buttons at the same time and then release.
- If LED1 flashes RED this indicates that the measured value is not close enough to the full scale value expected to allow calibration to be achieved.
- If full scale calibration has been achieved LED1 will go amber for 0.5 seconds as calibration values are learnt and saved to memory.
- To cycle which channel is being calibrated push the UP or DOWN buttons until the LED linked to the channel to be calibrated is lit. Repeat the above using the appropriate LED for the channel selected.

The analogue output can be scaled to any part of the full scale range of the transmitter connected.

For example an IWTT with a P100 input sends a temperature back between -200°C & 800°C. By default the 4-20mA output will be at 4mA at -200°C and 20mA at +800°C. the IWR-Set V2.1 software can be used to scale the 4-20mA so that 4mA is output at a temperature of 0°C and 20mA is output at a temperature of +500°C.

The set up procedure is intuitive once the IWR-SET software is opened on a PC and connected to the IWR receiver using a standard micro USB cable.

If switches 5 & 6 are configured to switch the Alarm Relay if wireless transmissions are missed the analogue output can also be set to go to a failsafe burnout output if no transmissions are received.

If a 4-20mA output is selected the output will go to 2.2mA if Low Burnout is selected or 22.8mA if High Burnout is selected.

If No Action (the default setting) is selected the analogue output will stay at the last valid value received from the connected transmitter.

#### 4. TROUBLE-SHOOTING GUIDE

<b>Problem encountered</b>	<b>Possible Causes</b>
LED 7 doesn't flash	The IWR receiver is not connected to a transmitter or the transmitters are out of range.
Any mA or Voltage Output channel reads zero	The IWR receiver output is not wired correctly, check wiring and try again. If wiring is OK check the 4-20mA or 1-5Vdc selector switch is in the right position.
Output from any IWR receiver channel isn't equivalent to the pressure or temperature being monitored by the appropriate transmitter.	Check that the IWR receiver is linked to the transmitter in question by pressing the pushbutton inside the transmitter and checking that LED 7 on the receiver flashes when the transmitter button is pressed.
As above	Check that the transmitter is set to the correct channel number using the internal DIP switch.
LED 6 Remains Permanently Lit	One of the transmitters is sending a value that is outside the alarm conditions or the receiver is out of range of one of the transmitters or one of the transmitters is switched OFF. The internal channel LEDs can be used to ascertain the channel initiating the alarm and the type of alarm.
LED 6 is flashing	This indicates that the battery inside the transmitter is running low. Change the battery inside the transmitter taking care to reset the battery level using the procedure outlined in the transmitter manual. The internal LEDs can be used to ascertain the channel initiating the low battery alarm.

## 5. SYSTEM PART NUMBERS

Pressure Transmitters		Temperature Transmitters	
Part Number	Pressure Range	Part Number	Transmitter Type
WPT-G1000-00	0-1 Bar g	WTTTP100A	PT100 6x100mm 1/4"BSP
WPT-G6000-00	0-6 Bar g	WTTTP150A	PT100 6x150mm 1/4"BSP
WPT-GM1P9-00	-1-+9 Bar g	WTTTP200A	PT100 6x200mm 1/4"BSP
WPT-G1002-00	0-10 Bar g	WTTTP250A	PT100 6x250mm 1/4"BSP
WPT-G1602-00	0-16 Bar g	WTTTP300A	PT100 6x300mm 1/4"BSP
WPT-CO184-00	-1-+24 Bar g	WTTTP400A	PT100 6x400mm 1/4"BSP
WPT-G2502-00	0-25 Bar g	WTTJ200A	J type 6x200mm 1/4"BSP
WPT-G4002-00	0-40 Bar g	WTTJ300A	J type 6x300mm 1/4"BSP
WPT-G1003-00	0-100 Bar g	WTTJ400A	J type 6x400mm 1/4"BSP
WPT-G2503-00	0-250 Bar g	WTTK150A	K type 6x150mm 1/4"BSP
WPT-G4003-00	0-400 Bar g	WTTK200A	K type 6x200mm 1/4"BSP
WPTU-GP015-00	0-15 psi g	WTTK300A	K type 6x300mm 1/4"BSP
WPTU-GP030-00	0-30 psi g	WTTK400A	K type 6x400mm 1/4"BSP
WPTU-CO446-00	-14.5 to +150 psi g	WTTUP100A	PT100 6x100mm 1/4"NPT
WPTU-GP075-00	0-75 psi g	WTTUP150A	PT100 6x150mm 1/4"NPT
WPTU-GP100-00	0-100 psi g	WTTUP200A	PT100 6x200mm 1/4"NPT
WPTU-CO447-00	-14.5 to +350 psi g	WTTUP250A	PT100 6x250mm 1/4"NPT
WPTU-GP150-00	0-150 psi g	WTTUP300A	PT100 6x300mm 1/4"NPT
WPTU-GP300-00	0-300 psi g	WTTUP400A	PT100 6x400mm 1/4"NPT
WPTU-GP750-00	0-750 psi g	WTTUJ200A	J type 6x200mm 1/4"NPT
WPTU-GP1K5-00	0-1500 psi g	WTTUJ300A	J type 6x300mm 1/4"NPT
WPTU-GP3K6-00	0-3600 psi g	WTTUJ400A	J type 6x400mm 1/4"NPT
WPTU-GP5K8-00	0-5800 psi g	WTTUK150A	K type 6x150mm 1/4"NPT
WPTL-G0050-00	0-50mbar G	WTTUK200A	K type 6x200mm 1/4"NPT
WPTL-G0100-00	0-100mbar G	WTTUK300A	K type 6x300mm 1/4"NPT
WPTL-G0250-00	0-250mbar G	WTTUK400A	K type 6x400mm 1/4"NPT
WPTL-G0500-00	0-500mbar G		
WPTL-G0750-00	0-750mbar G		
WPTL-G1000-00	0-1000mbar G		
WPTL-G0500-00	0-500mbar Abs		
WPTL-G0750-00	0-750mbar Abs		
WPTL-G1000-00	0-1000mbar Abs		
WPTLU-GP001-00	0-1 psi g		
WPTLU-GP002-00	0-2 psi g		
WPTLU-GP005-00	0-5 psi g		
WPTLU-GP008-00	0-8 psi g		
WPTLU-GP010-00	0-10 psi g		
WPTLU-GP015-00	0-15 psi g		
WPTLU-GP005-00	0-5 psi Abs		
WPTLU-GP010-00	0-10 psi Abs		
WPTLU-GP015-00	0-15 psi Abs		

Part Number	Number of Output Channels
IWR-5	One
IWR-5	Five
IANT-3	3dBi Antenna
IWPT-SW	Swivel Adaptor (1/4"BSP) for pressure transmitters only

## 6. SPECIFICATIONS

System Performance	
Accuracy (non-linearity & hysteresis)	<±0.25% / FS (BFSL)
Setting Errors	Zero & Full Scale, <±0.5% / FS
Operating Temperature	-20 to +50 °C
Storage Temperature	-20 to +80 °C
Outputs x 5	4-20mA current source 1-5 Vdc voltage source
Relay	5A rated changeover contact
Enclosure Material	Light Grey ABS (RAL 7035)
Weight	285g
RF Transmitter	Contains FCC W&)MRF24J40MDME
Power Requirements	12 to 32 Vdc
Fuse	Internal resettable fuse
Dimensions	160 x 80 x 57mm (L x W x D)
Mounting	Any Orientation

---

Industrial Interface Systems Ltd  
Units 68 & 69 Basepoint Business Centre  
Oakfield Close, Tewkesbury, GL20 8SD, United Kingdom  
Tel: +44(0)1684 854464, email: sales@industrialinterface.co.uk

[www.industrialinterface.co.uk](http://www.industrialinterface.co.uk)